

1 Unilift AP12.50.11.A3



3-
F.

0,8

10

12

10

: 0..55 °C
998.2 / 3

	:	12
	:	
	:	
	:	DIN W.-Nr. 1.4301
	:	AISI 304
	:	
	:	DIN W.-Nr. 1.4301
	:	AISI 304
	:	
	:	Rp 2
	:	7
	:	
	:	- P1: 1.9
	:	50 Hz
	:	3 x 400
	:	3.2 A
Cos phi -	:	0,88
	:	2785 /
	:	(IEC 34-5): IP68
	:	(IEC 85): F
	:	10
	:	CEE
	:	
	:	17.9
	:	18.7

Unilift AP12.50.11.A3 50

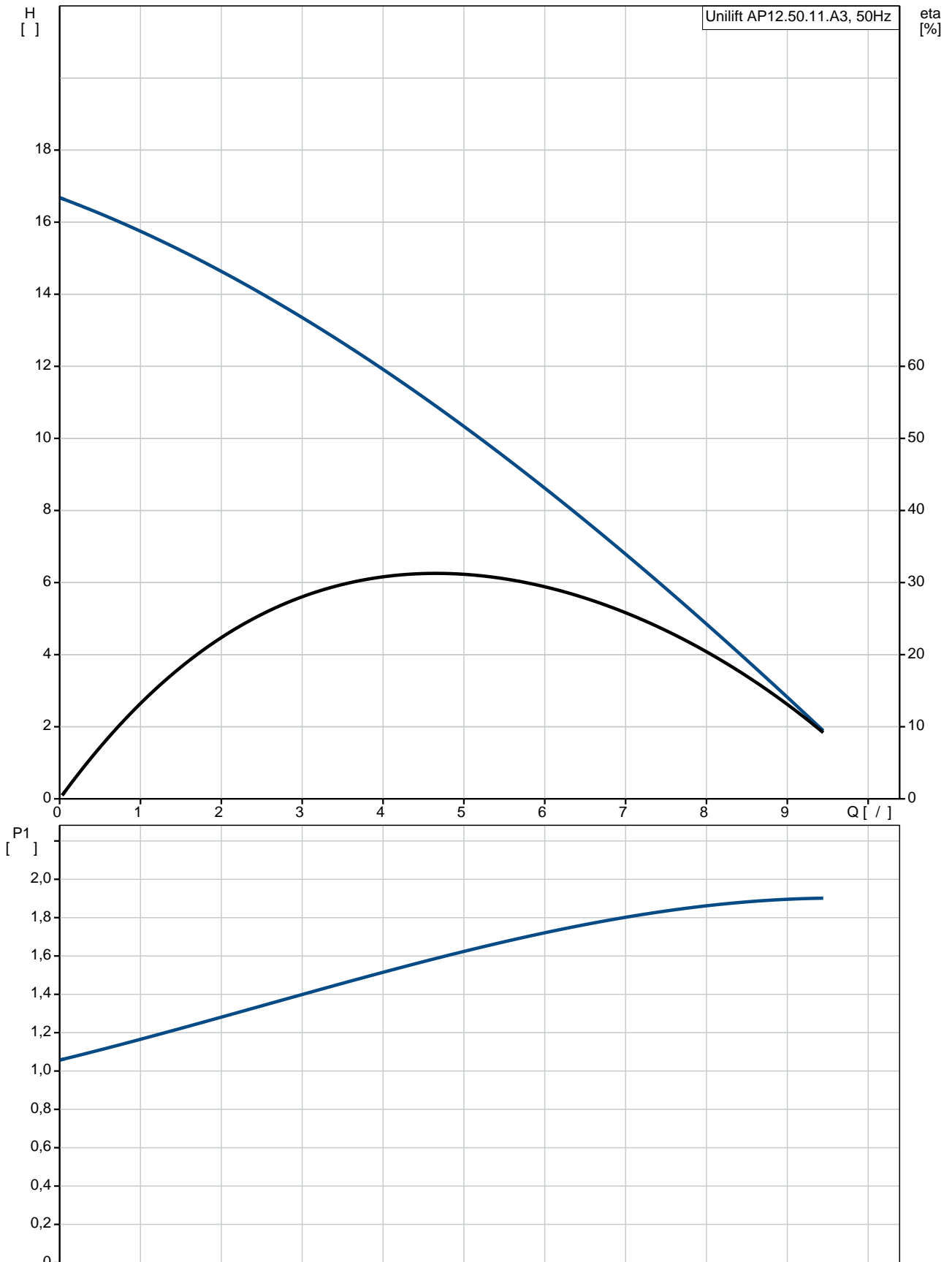

Unilift AP12.50.11.A3

EAN :

Ma : 8.89 /
: 18
: 12

DIN W.-Nr. 1.4301
AISI 304

DIN W.-Nr. 1.4301
AISI 304

Rp 2
: 7
/ : D/S

: 0 .. 55 °C
: 998.2 / ³

- P1: 1.9
P2: 1.2
: 50 Hz
: 3 x 400
: 3.2 A
Cos phi - : 0,88
: 2785 /
(IEC 34-5): IP68
(IEC 85): F

10
CEE

17.9
18.7

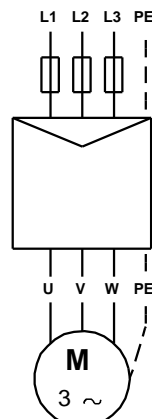
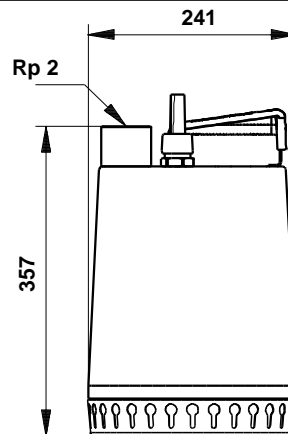
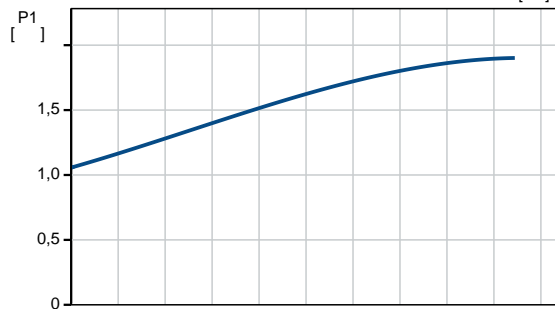
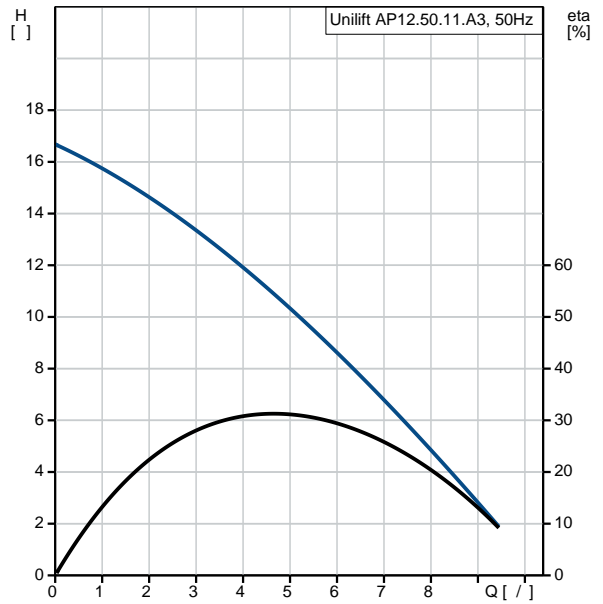

Unilift AP12.50.11.A3 50

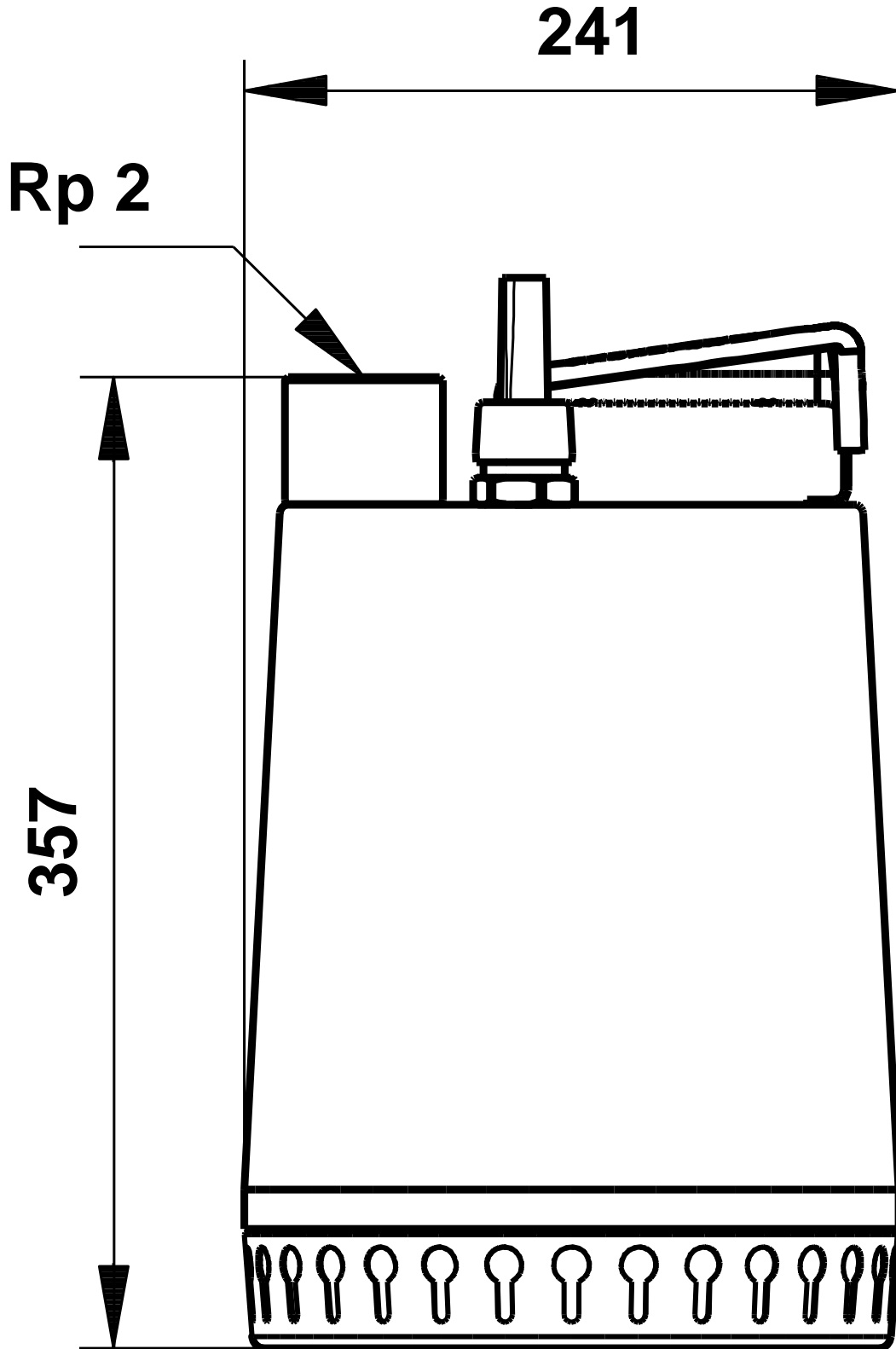

Unilift AP12.50.11.A3 50

