

1 **MAGNA3 50-120 F**

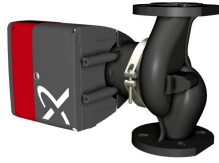

MAGNA3 –

, MAGNA3

Grundfos

MAGNA3 -

MAGNA3 -

- 
- 
- 
- 
- 
- 
- 
- 
- 

TFT-

CIM-

MAGNA3

- AUTOADAPT (

- FLOWADAPT (

) FLOWLIMIT (

)(

MAGNA3

Grundfos (Grundfos GO Remote)

- 
- 

CIM-

MAGNA3  
( - )

4-

: -10 .. 110 °C  
: 60 °C  
: 983.2 / ³

TF

: 110  
: CE,VDE,EAC,CN ROHS

: EN-GJL-250  
: ASTM A48-250B  
: PES 30%GF

: 0 .. 40 °C

: 10  
: DIN  
: DN 50  
: PN6/10  
: 280

: -P1: 20 .. 513  
: 50 Hz  
: 1 x 230  
: 0.22 .. 2.3 A

(IEC 34-5): X4D  
(IEC 85): F

: (EEI): 0.17  
: 18.2  
: 20.3  
: 0.046 ³

## MAGNA3 50-120 F 50

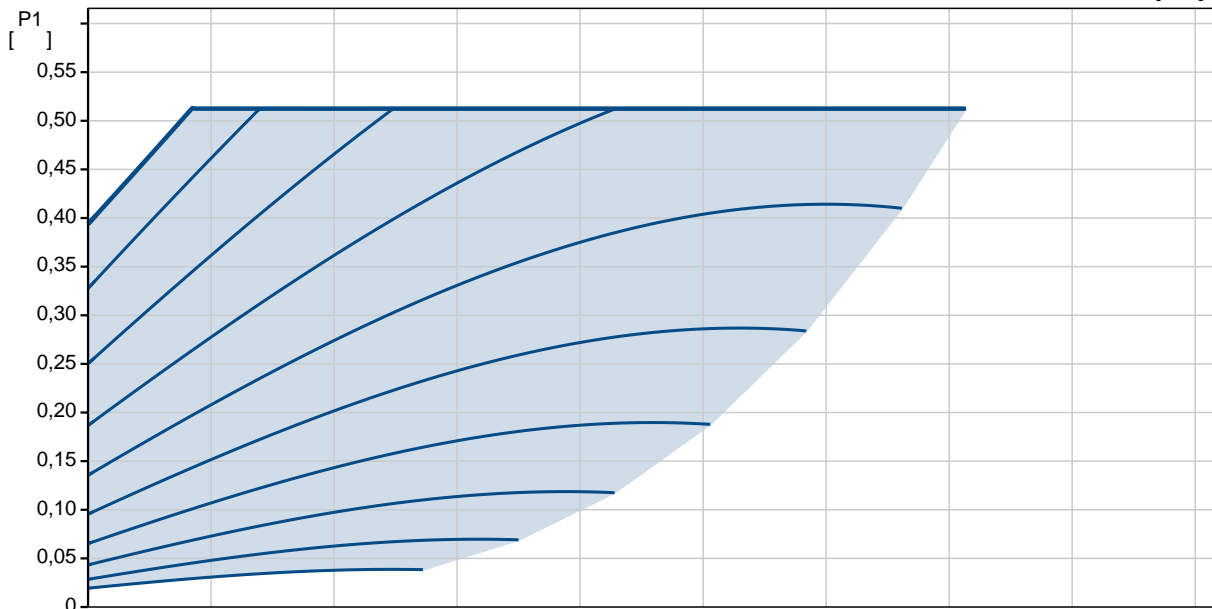
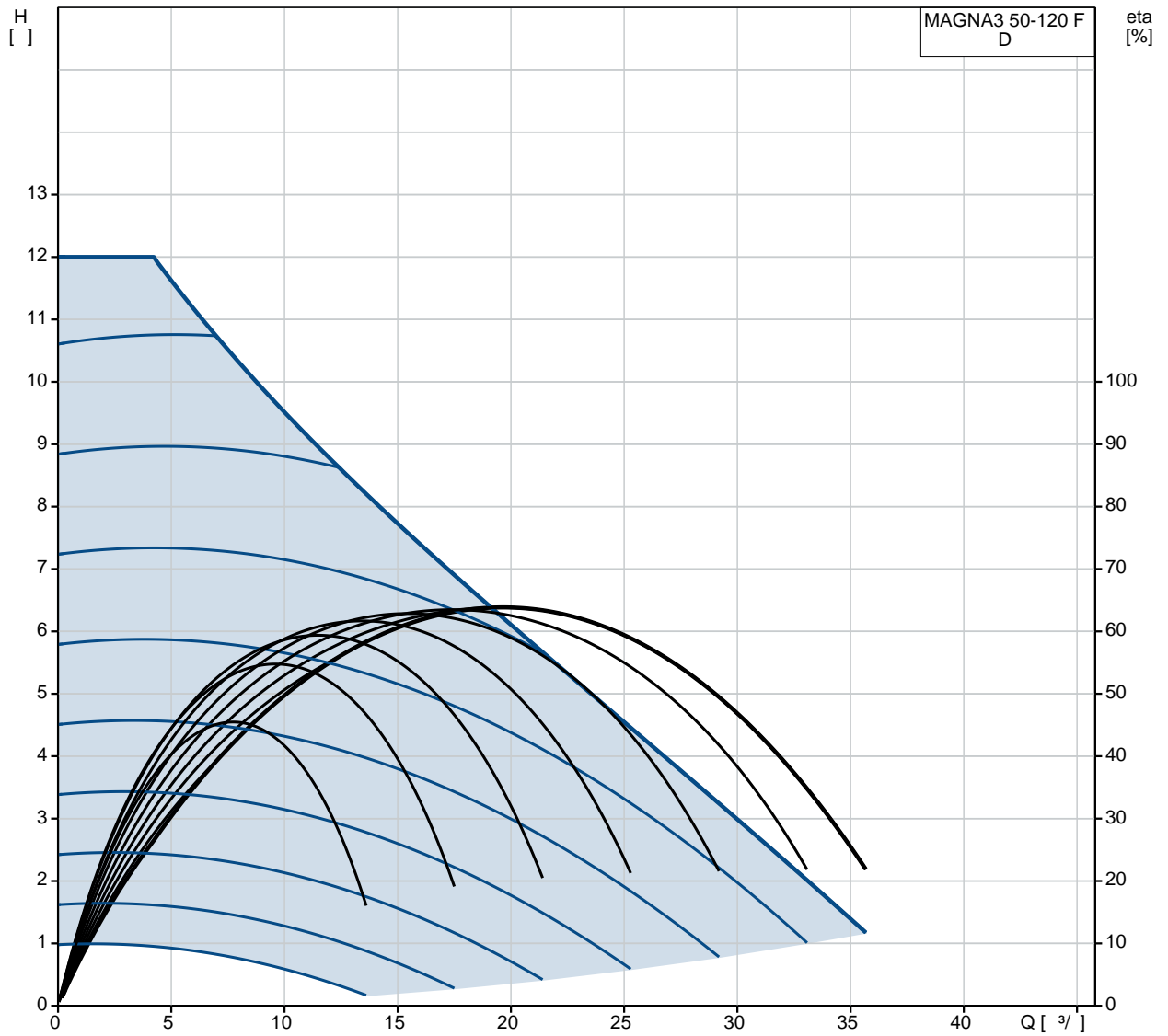

MAGNA3 50-120 F

EAN :

TF :

120  
110  
CE, VDE, EAC, CN ROHS  
D

EN-GJL-250  
ASTM A48-250B  
PES 30%GF

0 .. 40 °C

10  
DIN  
DN 50  
PN6/10  
280

-10 .. 110 °C  
60 °C

983.2 / <sup>3</sup>

-P1: 20 .. 513  
50 Hz  
1 x 230  
0.22 .. 2.3 A  
(IEC 34-5): X4D  
(IEC 85): F

(EEI): 0.17  
18.2  
20.3  
0.046 <sup>3</sup>

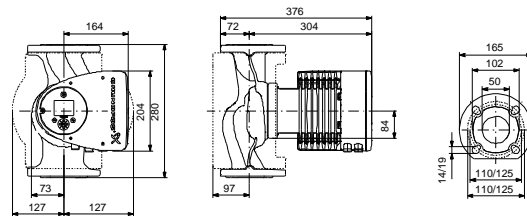
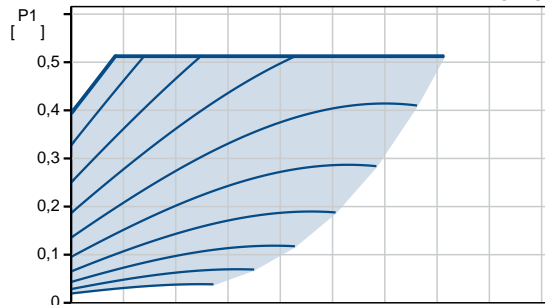
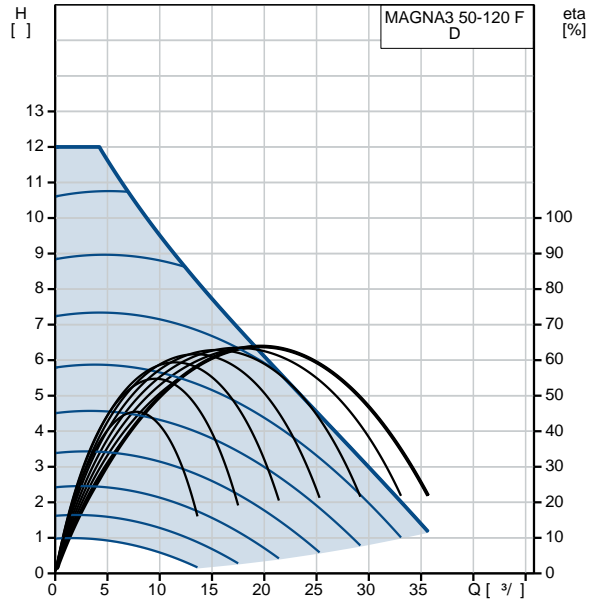

Example of mains-connected motor with mains switch, backup fuse and additional protection

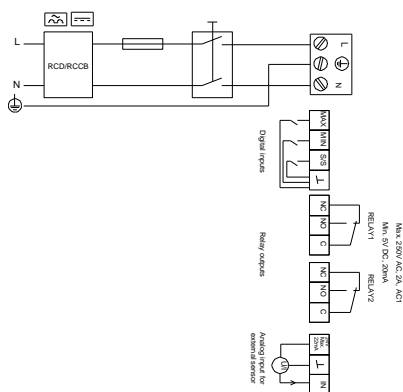

**MAGNA3 50-120 F 50**

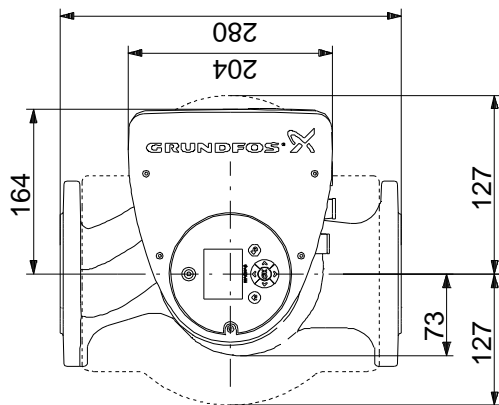
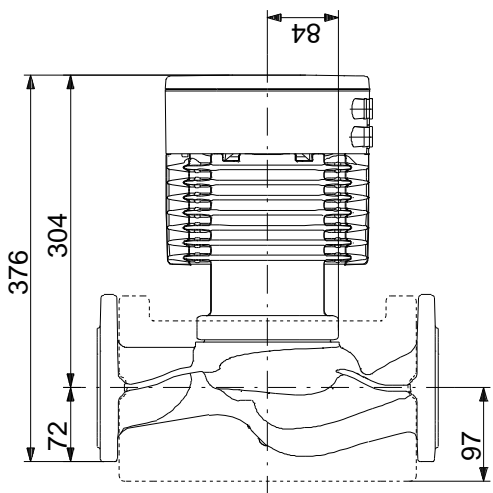
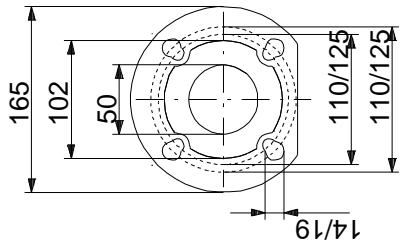

! [ ] :

## MAGNA3 50-120 F 50

Example of mains-connected motor with mains switch, backup fuse and additional protection

