

1 UPS 15-60 130



: 96281471

, PES/PP.

1-

: 2 .. 110 °C
 20 °C
 998.2 / 3

TF

110
 : VDE,AAA,EAC

EN-JL1030
 ASTM 30 B
 , PES/PP

.T

80 0C: 40 °C

10
 G 1
 PN 10
 130

C : 2.5
 1: 50
 2: 60
 3: 70
 : 50 Hz
 : 1 x 230 V
 1: 0.22 A
 2: 0.27 A
 3: 0.3 A
 : 2.5
 (IEC 34-5): IP44
 (IEC 85): F
 :
 :
 : 2.3
 : 2.5
 : 0.004 3

96281471 UPS 15-60 130 50

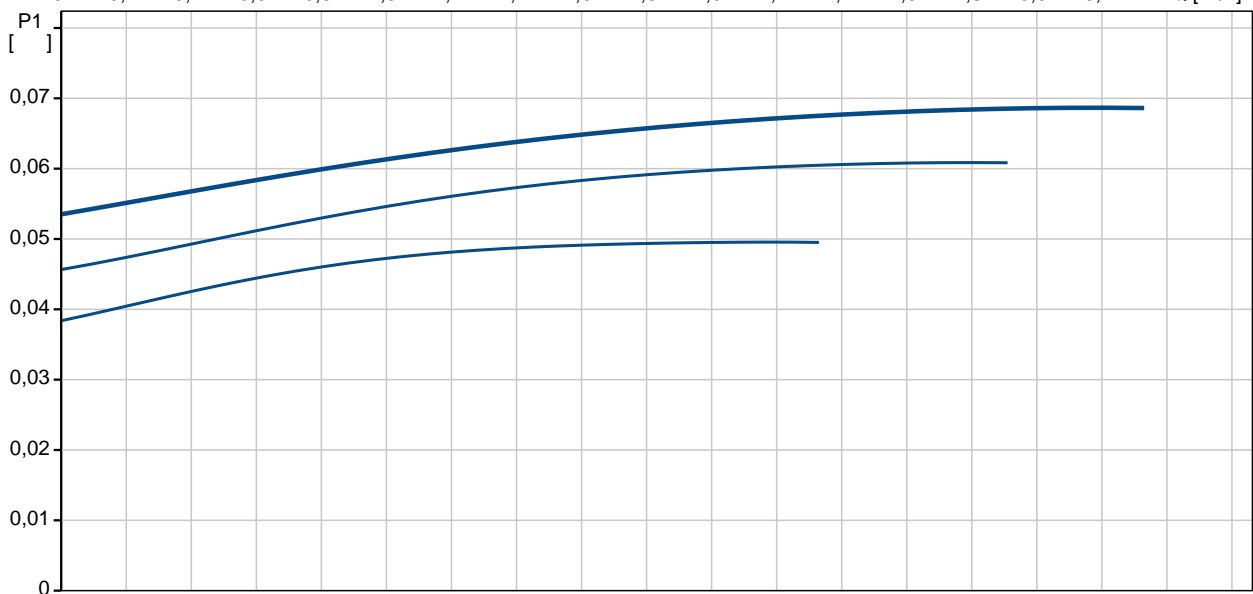
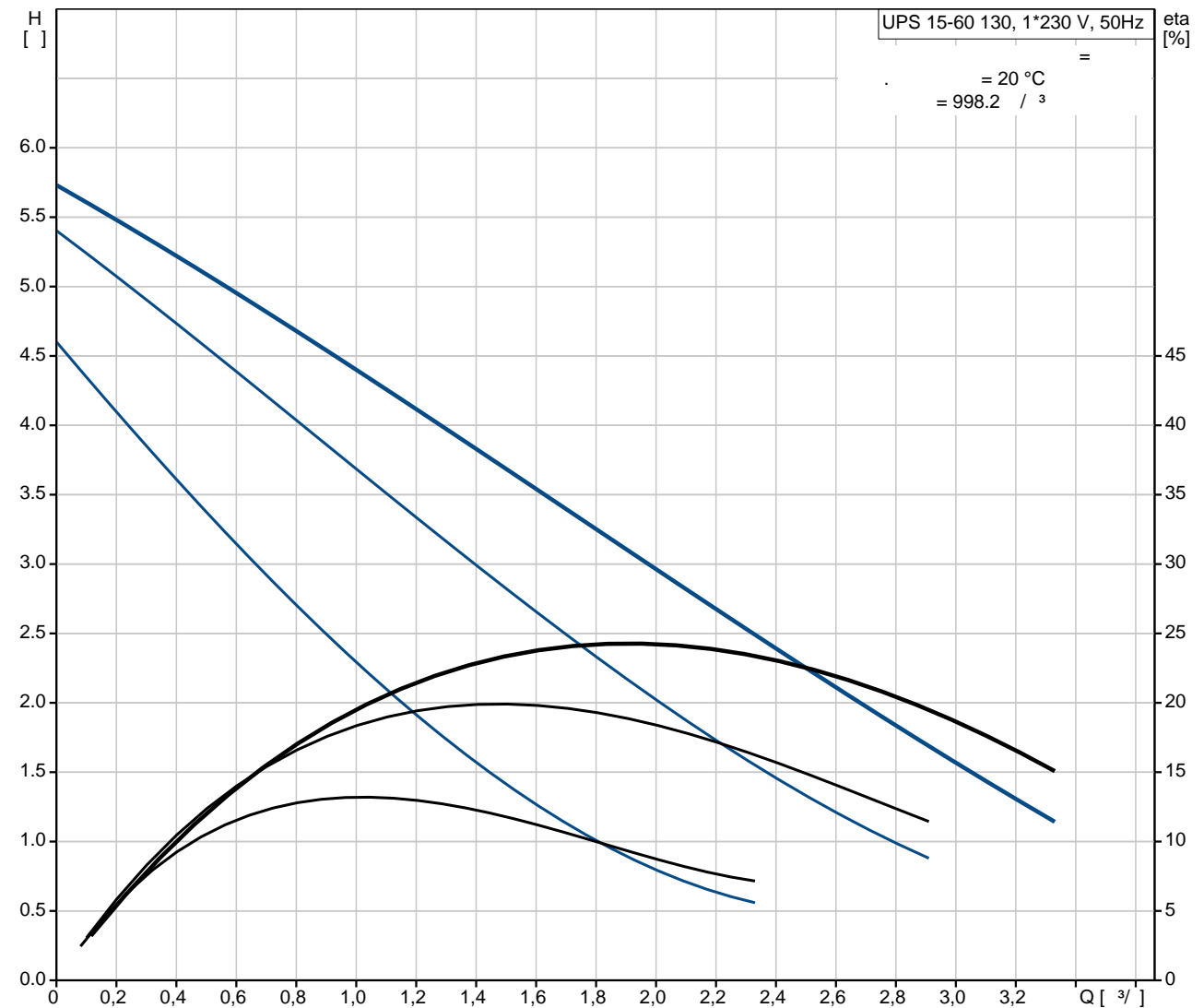

UPS 15-60 130	
EAN : 96281471	
5700830458259	
TF :	3
	60
	110
	VDE,AAA,EAC
	EN-JL1030
	ASTM 30 B
	, PES/PP
.T	40 °C
80 OC:	
	10
	G 1
	PN 10
	130
	2 .. 110 °C
	20 °C
	998.2 / ³
C :	2.5
1:	50
2:	60
3:	70
	50 Hz
	1 x 230 V
	1: 0.22 A
	2: 0.27 A
	3: 0.3 A
	2.5
(IEC 34-5):	IP44
(IEC 85):	F
	9H
	2.3
	2.5
	0.004 3

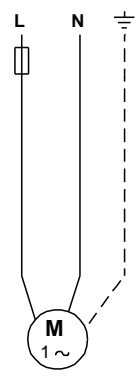
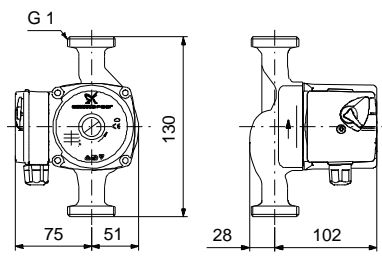
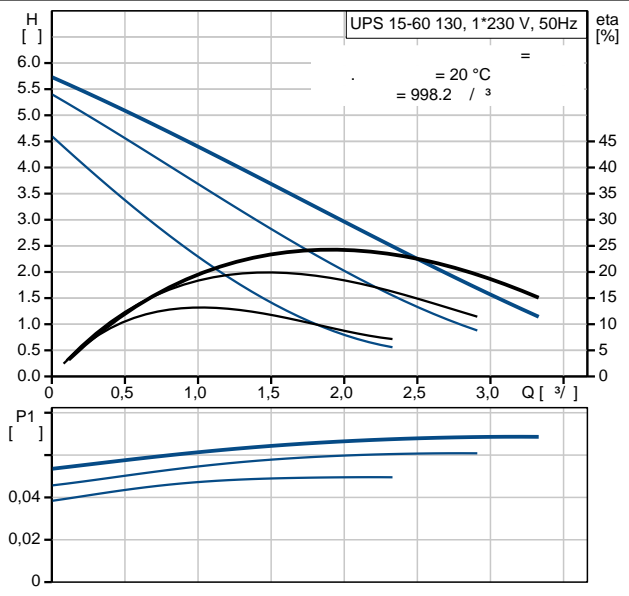

96281471 UPS 15-60 130 50

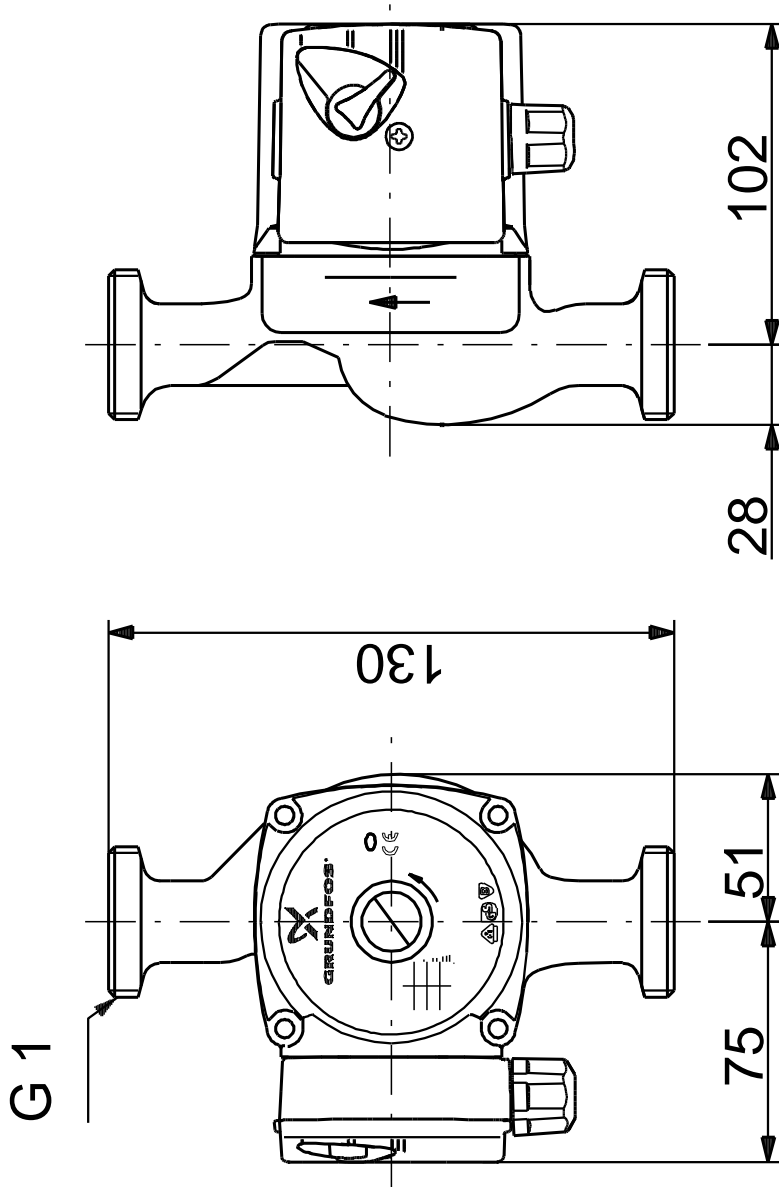

96281471 UPS 15-60 130 50

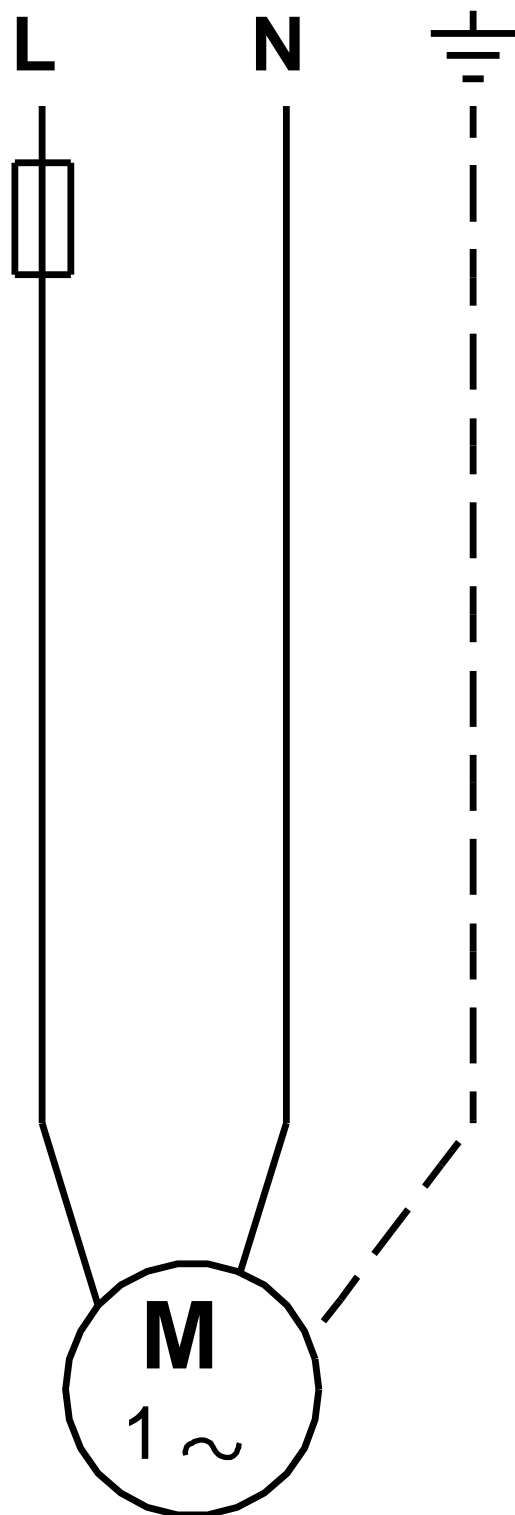

! []